

Features

- Pb free product—RoHS compliant
- Low power consumption, High efficiency
- Reliable and rugged
- Long life – solid state reliability
- Fast response time
- High photo sensitivity

Package Dimension

Notes:

1. All dimensions are in millimeters.
- 2.

Electrical Optical Characteristics at Ta=25

Parameter	Symbol	Min.	Typ.	Max.	Unit	Test Condition
	0.5	780	---	1100	nm	---
	P	---	940	---	nm	---
Collector-Emitter Breakdown Voltage	BV_{CEO}	30	---	---	V	$I_C=0.1mA$ $E_e=0mW/cm^2$
Emitter-Collector Breakdown Voltage	BV_{ECO}	5	---	---	V	$I_E=0.1mA$ $E_e=0mW/cm^2$
Collector-Emitter Saturation Voltage	$V_{CE(SAT)}$	---	---	0.4	V	$I_C=0.1mA$ $E_e=1mW/cm^2$
						$V_{CE}=5V$ $I_C=1mA$ $R_L=1000$
Viewing Angle	1/2	---	50	---	Deg.	---
Collector Dark Current	I_{CEO}	---	---	100	nA	$V_{CE}=10V$ $E_e=0mW/cm^2$
On State Collector Current	$I_{C(ON)}$	1.0	---	---	mA	$V_{CE}=5V$ $E_e=1mW/cm^2$

Note:

1/2 is the off-axis angle at which the $I_{C(ON)}$ is half the axial $I_{C(ON)}$.

2. The $I_{C(ON)}$ guarantee should be added $\pm 15\%$ tolerance.



Carrier Tape Specifications

Note: Tolerance unless mentioned is ± 0.1 mm; Unit = mm

Moisture Resistant Packaging

Suggest IR Reflow Condition For Lead Free

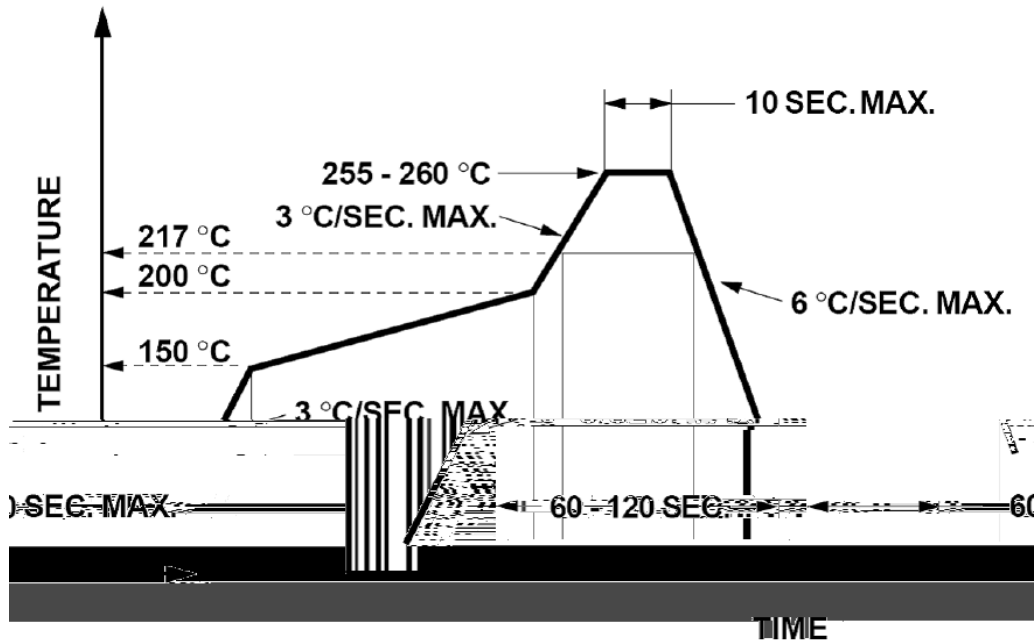

1. Reflow soldering should not be done more than two times.
2. When soldering, do not put stress on the LEDs during heating.

Soldering iron

1. When hand soldering, the temperature of the iron must less than 300°C for 3 seconds.
2. The hand solder should be done only once.

Repairing

Repair should not be done after the LEDs have been soldered. When repairing is unavoidable, a double-head soldering iron should be used (as below figure). It should be confirmed beforehand whether the characteristics of LEDs will or will not be damaged by repairing.

