

SL-T3510RGBA-L120

DATA SHEET

SPEC.NO.: SZ18040901
DATE: 2018/04/09
REV. A/0

Approved By:

Checked By:

Prepared By:

SL-T3510RGBA-L120**TOP Full-color LED****Technical Data Sheet**

These products are full-color SMD component and designed for outdoor display with white refractor, high brightness,



Typical Characteristics Curves

Volt Ampere Characteristics

Forward Current mA

Relative Luminous Intensity VS Forward Current

Relative Luminous Intensity

Forward Current mA

Forward Current Derating Curve

Forward Current mA

Ambient Temperature

Relative Spectral Distribution

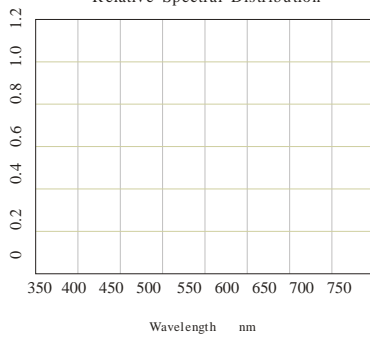

Reliability Test Items And Conditions

Test Items	Reference	Test Conditions	Time
Thermal Shock	MIL-STD-202G	-40 (30min)←→100 (30min)	300 300 cycles
Temperature And Humidity Cyclic	JEITA ED-4701 200 203	-10 ———+65 0%-90%RH 24hrs./1cycle	10 10 cycles
High Temperature Storage	JEITA ED-4701 200 201	Ta=100	1000h
Low Temperature Storage	JEITA ED-4701 200 202	Ta=-40	1000h
High Temperature High Humidity Storage	JEITA ED-4701 100 103	Ta=60 RH=90%	1000h
Life Test	JESD22-A108D	Ta=25 IF _R =15mA,IF _G =8mA,IF _B =5mA	1000h
High Temperature Life Test	JESD22-A108D	Ta=85 IF _R =15mA,IF _G =8mA,IF _B =5mA	1000h
Low Temperature Life Test	JESD22-A108D	Ta=-40 IF _R =15mA,IF _G =8mA,IF _B =5mA	1000h
Resistance to Soldering Heat	GB/T 4937, .2.2&2.3	Tsol*=260 10sec.	2 2 times

Criteria For Judging Damage

Test Items	Symbol	Test Conditions	Criteria For Judging Damage
			295.61/1000h (2) (3) (4) (5) (6) (7) (8) (9) (10) (11) (12) (13) (14) (15) (16) (17) (18) (19) (20) (21) (22) (23) (24) (25) (26) (27) (28) (29) (30) (31) (32) (33) (34) (35) (36) (37) (38) (39) (40) (41) (42) (43) (44) (45) (46) (47) (48) (49) (50) (51) (52) (53) (54) (55) (56) (57) (58) (59) (60) (61) (62) (63) (64) (65) (66) (67) (68) (69) (70) (71) (72) (73) (74) (75) (76) (77) (78) (79) (80) (81) (82) (83) (84) (85) (86) (87) (88) (89) (90) (91) (92) (93) (94) (95) (96) (97) (98) (99) (100)

1

Packaging (1)

◇ Carrier Tape

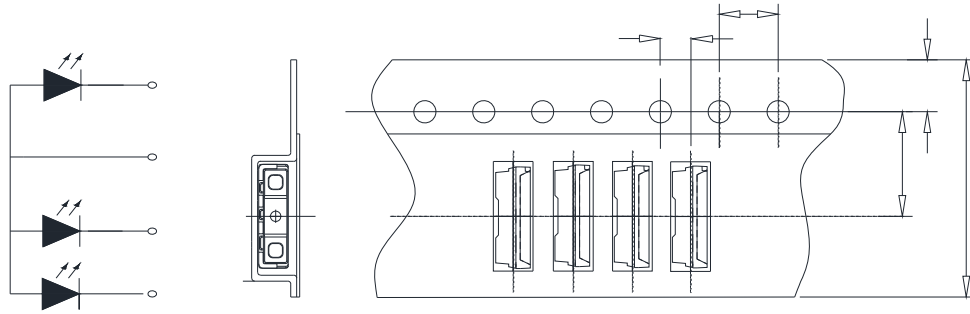

All dimensions in mm, tolerances unless mentioned is 0.10 mm. f

◇ Details Of Carrier Tape

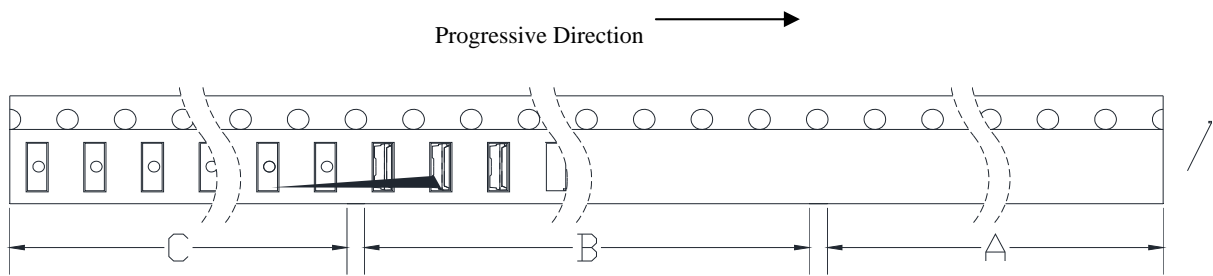

◇ Reel Dimension

Label

2

Packaging(2)



Moisture Proof and Anti-Electrostatic Foil Bag

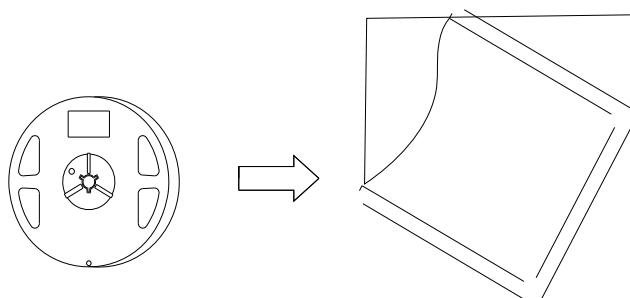

Cardboard Box



Label Explanation

TYPE

QTY Quantity

BIN Rank

SC: Bin Code

LOT Lot Number

λ d Wavelength Range

IV Luminous Intensity Range

VF Forward Voltage Range

IF Test Current

LIGHT



2



Guideline for Soldering (2)

Reflow soldering should not be done more than one time.

LED

Stress on the LEDs should be avoided during heating in the reflow soldering process.

After soldering, do not deal with the product before its temperature drop down to room temperature.

3.

Cleaning

	30	3	50
30		LED	

It is recommended that alcohol Anhydrous ethanol be used as a solvent for cleaning after soldering.

Cleaning is to go under 30 for 3 minutes or 50 for 30 seconds. When using other solvents, it should be confirmed beforehand whether the solvents will dissolve the package and the resin or not.

300W LED

LED

Ultrasonic cleaning is also an effective way for cleaning. The influence of Ultrasonic cleaning on LED depends on factors such as ultrasonic power. Generally, the ultrasonic power should not be higher than 300W, otherwise it will cause LED damage. Before cleaning, a pre-test should be done to confirm if any damage to LEDs will occur.

PCB

(1)

Precautions (1)

1.

Storage

-

Moisture proof, anti-electrostatic package and moisture absorbent material are used, to keep moisture to a minimum. Humidity indicator card inside to test if the products are moisted.

- <30 <60 RH 2

Storage environment: Before opening the package, the product should be kept at 30 or less and humidity less than 60% RH, When the storage time more than 2 months, need to be used to bake.

-

Before using, please check whether there is any air leakage or not, If the bag has leaked air, Please bake the product with below condition.

- <30 <60 RH 12h

Before soldering ,the product must be stored under the condition of <30 and <60 RH. Under these conditions the SMD LEDs must be used (subject to reflow oven) within 12 hours.

- 70±5 24h

Baking conditions: 70±5 24h.

2.

Static Electricity

-

Static electricity or surge voltage damages the LEDs. Damaged LEDs will show some unusual characteristics such as the forward voltage becomes lower, or the LEDs can not be lighted up. In view of the above, we should do some anti-static precautions when using the SMD LEDs.

-

All devices, equipments and machineries must be properly grounded, at the same time we should take measures to prevent anti-static and voltage surge.

-

It is also recommended that anti-electrostatic wrist bands, pads, uniforms, gloves or containers can be used when dealing with the LEDs.

(2)

Precautions (2)

3.

Design Consideration

- LED

In designing a circuit, the current through each LED must not exceed the absolute maximum rating specified for each LED. In the meanwhile, resistors for protection should be applied, otherwise slight voltage shift will cause big current change which will probably lead to damage.

- A LED B LED
LED V_F LED

It is recommended to use Circuit A which regulates the current flowing through each LED rather than Circuit B. When driving LEDs with a constant voltage in Circuit B, the current through the LEDs may vary due to the variation in Forward Voltage (V_F) of the LEDs. In the worst case, some LED may be subjected to stress in the excess of the Absolute Maximum Rating.

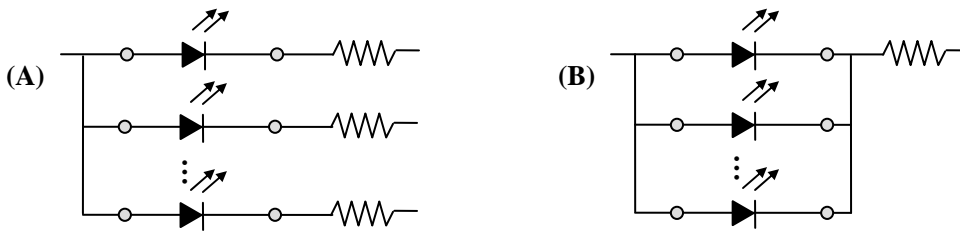

- LED LED

Thermal Design is paramount importance because heat generation may result in the Characteristics decline, such as brightness decrease, Color change and so on. Please consider the heat dissipation when making the system design.

4.

Reverse voltage protection

- LED LED
LED LED
LED 5V

In general, the reverse current of LED is very small, which won't affect the normal use of components. But when it is often suffered the reverse voltage which exceeds the limit of the component then it will be damaged.

(3)

Precautions (3)

Such as the reverse current increase rapidly. And it will cause the string light when the screen is black. So please pay attention to controlling the reverse voltage which less than 5V is recommended.

5.

The safe temperature for LEDs working

- LED

55

75

The high temperature will make the LEDs' Luminous Intensity decreased radically, if LEDs are used in hot environment for a long time, they will be disabled easily. When LEDs are used in a high density array, we suggest that the LEDs' surface temperature should be lower than 55 and the legs' temperature should be lower than 75 .

6.

Others

-

When handling the product, touching the encapsulation with bare hands will not only contaminate its surface, but also have an effect on its optical characteristics. Excessive force to the encapsulation might result in catastrophic failure of the LEDs due to die breakage or wire deformation. For this reason, please do not put excessive stress on LEDs, especially when the LEDs are heated such as during Reflow Soldering.

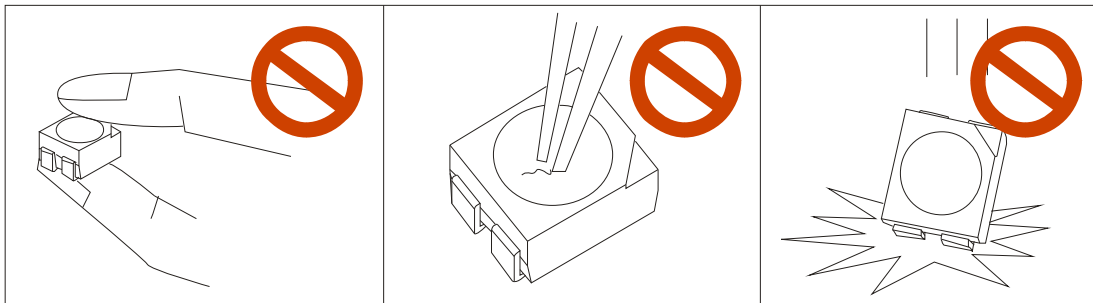

- LED

The epoxy resin of encapsulation is fragile, so please avoid scratch or friction over the epoxy resin surface.

While handling the product with tweezers, do not hold by the epoxy resin, be careful.